

Raspberry Pi Expansion Card  
Analog Input Board 12bit ADC  
**CPI-AI-1208LI**

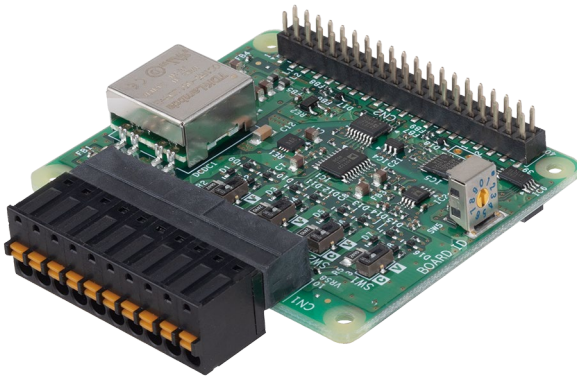

This product is an expansion card that adds an analog Input interface to the Raspberry Pi.  
It has analog Inputs with 12-bit resolution.  
One card can be used as single-ended voltage input with 8 channels, differential voltage input with 4 channels, or differential current input with 4 channels and the functions are switchable.

- \* Specifications, color and design of the products are subject to change without notice.
- \*The contents in this document are subject to change without notice.
- \*Visit the CONTEC website to check the latest details in the document.
- \*The information in the data sheets is as of July, 2023.

**Features**

**Bus Isolated Analog Input**

This product contains bus isolated analog voltage input and analog current input.  
As the analog input supports differential input, accurate measurement can be performed even when potential differences with the signal source occur.

**Capable of supporting multiple input range and types**

The voltage input and current input is switchable in the switch setting of expansion cards.  
For voltage input, the input range and input type (single-ended input or differential input) can be switched by software command.  
For current input, the differential input type is ± 20mA range.

**Connectivity for up to 8 cards**

Connect up to 8 expansion cards of the same series. Use the Board ID setting switch on the main body to identify connected expansion cards.

\* The Board ID setting switch cannot be set to 4 when using the CPI-RAS.

**Adaptable to a wide range of temperature between -20 and +60°C**

The product is capable of operating in the temperature between -20 and + 60°C. It can be installed in the various environments.

**No electrolytic capacitor**

Without an electrolytic capacitor, which has a limited life, we are creating the product with a longer life.

**Linux compatible driver software**

Using the analog I/O driver API-AIO(LNX) makes it possible to create applications of Linux.

**List of Option**

Product Name	Model type	Description
RAS card	CPI-RAS	RAS/RTC function, 8 to 28 VDC input function expansion.
DIN RAIL ADAPTER	CPI-DIN01	

\* Information about the option products, see the Contec's website.

**Specifications**

**Function specification**

Item	Description
Analog Input	
Input type *1	Single-Ended Input or Differential Input (Set by software command)
Input range*1	Voltage input *4
	Current *4
Maximum input rating	At voltage input: ±15V At current input: ±24mA
Input impedance	At voltage input: 1MΩ or more (Power ON), 10kΩ or more (Power OFF) At current input: 249Ω±1%
Input channel	8ch (Single-Ended Input), 4ch (Differential Input) * Current input is supported for differential input only.
Resolution	12-bit
Non-Linearity error *2	At voltage input: ±10LSB At current input: ±20LSB
Conversion rate	Differ by the software
Buffer memory	None
Conversion start trigger	Software
Isolation	Bus Isolation
Voltage resistance	500VAC
Cable Length	For voltage : 1.5 meters approx. (vary depending on the wiring environment) For current : 20 meters approx. (vary depending on the wiring environment)
Bus specification	I2C bus (I2C1)
Max. module count for connection	Maximum of 8cards *3
Connector	2 pieces 3.81mm pitch 10-pin terminal
Applicable wire	AWG28 - 16
Electricity consumption	5VDC 240mA (Max) 3.3VDC 1mA (Max)
Physical dimensions (mm)	65.0(W) x 56.5(D) (No protrusions) Spacer height: 12.5mm
Weight	50g

- \*1 All the input channels of range and types should be switched together simultaneously.
- \*2 The non-linearity error means an error of approximately 0.1% occurs over the maximum range at -20°C and 60°C ambient temperature.
- \*3 The Board ID setting switch cannot be set to 4 when using the CPI-RAS.
- \*4 Voltage input and current input are switchable in the Input switches of expansion cards.

### Installation Environment Requirements

Item	Description	
Operating Temperature	-20 - +60°C	
Storage Temperature	-20 - +60°C	
Humidity	10 - 90%RH (No condensation)	
Floating dust particles	Not to be excessive	
Corrosive gases	None	
Line-noise resistance *1	Line noise	Signal Line /± 1kV (IEC61000-4-4 Level 3, EN61000-4-4 Level 3)
	Static electricity resistance	Indirect discharge /± 4kV (IEC61000-4-2 Level 2, EN61000-4-2 Level 2)
Vibration resistance	Sweep resistance	10 - 57Hz/semi-amplitude vibration 0.15mm, 57 - 150Hz/2.0G 40minutes each in X, Y, and Z directions (JIS C60068-2-6-compliant, IEC60068-2-6-compliant)
Shock resistance		15G half-sine shock for 11ms in X, Y, and Z directions (JIS C 60068-2-27 -compliant, IEC 60068-2-27 -compliant)
Standard		VCCI Class A, FCC Class A, CE Marking (EMC Directive Class A, RoHS Directive)

\*1 When using the CPI-RAS.

### Packing List

- Product [CPI-AI-1208LI] ...1
- 10-pin Connector ...1 (Attached to the product)
- 40-pin Pin-header...1
- Plastic Spacer for CPU Card...1
- Hexagonal Spacers...4 (Height 12.5mm)
- Three-point Sems Screw...4
- Nuts...4
- Product Guide & Warranty Certificate...1
- Serial Number Label ...1

### Support Software

You can use CONTEC support software according to your purpose and development environment. For more details on the supported OS, applicable languages, or to download the latest version of software, visit the CONTEC Web site.

Name	Contents	How to get
Driver software API-AIO(LNX)	This is the Linux version driver software provided in API function formats. The software includes various sample programs such as gcc (C, C++) and Python programs.	Download from the CONTEC website

Download the files from the following URL. <https://www.contec.com/download/>

### Physical Dimensions

#### Main body only

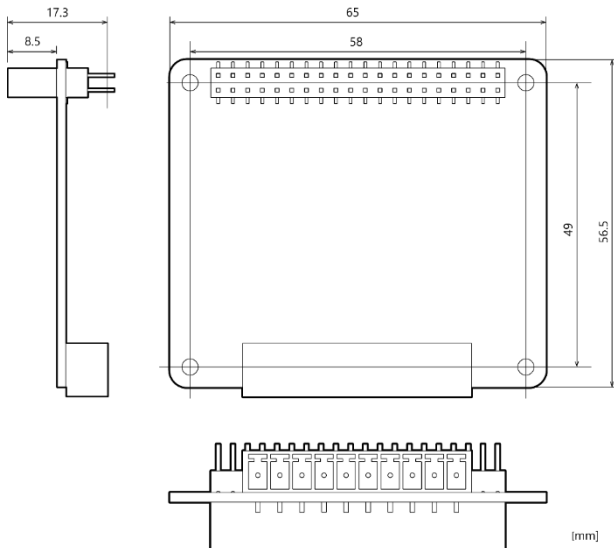

#### With connector attached

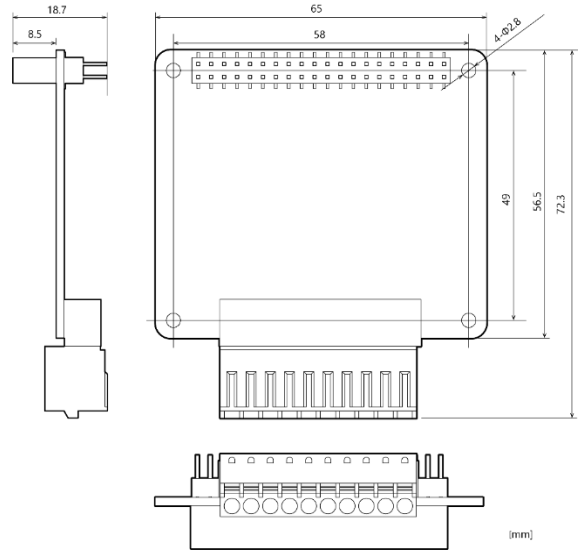

### Component Name

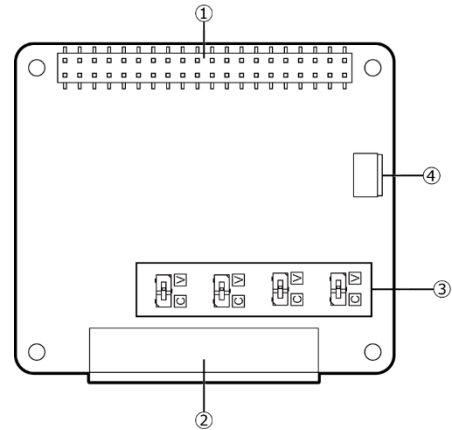

No.	Name	Function
1	GPIO 40 pin connector	This connector is used to connect to a Raspberry Pi or an expansion card.
2	Interface connector	This is a connector for analog output. Use the 10-pin connector included in the package.
3	Input switches	Use these switches to switch between "voltage input" and "current input".
4	Board ID setting switch	This setting switch is used to identify I2C communication expansion cards. The switch is used to change the I2C address.

**Connection to external devices**

**GPIO 40 pin connector**

This connector is used to connect to a Raspberry Pi or an expansion card.

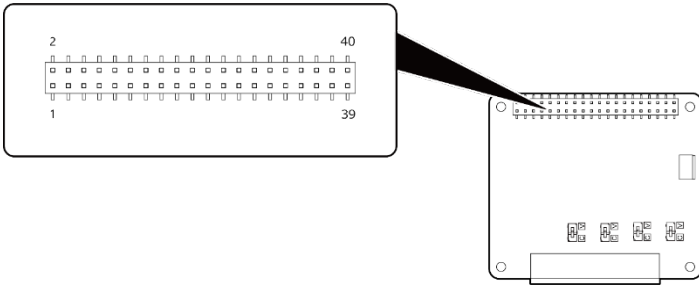

**Pin Assignment**

Pin No.	Signal Name	Description	Pin No.	Signal Name	Description
1	3.3V Power	3.3V power supply	2	5V Power	5V power supply
3	GPIO 2(I2C1 SDA)	I2C1 SDA	4	5V Power	5V power supply
5	GPIO 3(I2C1 SCL)	I2C1 SCL	6	Ground	GND
7	GPIO 4(GPCLK0)	(Don't use)	8	GPIO 14(UART TX)	(Don't use)
9	Ground	GND	10	GPIO 15(UART RX)	(Don't use)
11	GPIO 17	(Don't use)	12	GPIO 18(PCM CLK)	(Don't use)
13	GPIO 27	(Don't use)	14	Ground	GND
15	GPIO 22	(Don't use)	16	GPIO 23	(Don't use)
17	3.3V Power	3.3V power supply	18	GPIO 24	(Don't use)
19	GPIO 10(SPI0 MOSI)	(Don't use)	20	Ground	GND
21	GPIO 9(SPI0 MISO)	(Don't use)	22	GPIO 25	(Don't use)
23	GPIO 11(SPI0 SCLK)	(Don't use)	24	GPIO 8(SPI0 CE0)	(Don't use)
25	Ground	GND	26	GPIO 7(SPI0 CE1)	(Don't use)
27	GPIO 0(EEPROM SDA)	I2C0 SDA	28	GPIO 1(EEPROM SCL)	I2C0 SCL
29	GPIO 5	(Don't use)	30	Ground	GND
31	GPIO 6	(Don't use)	32	GPIO 12(PWM0)	(Don't use)
33	GPIO 13(PWM1)	(Don't use)	34	Ground	GND
35	GPIO 19(PCM FS)	(Don't use)	36	GPIO 16	(Don't use)
37	GPIO 26	(Don't use)	38	GPIO 20(PCM DIN)	(Don't use)
39	Ground	GND	40	GPIO 21(PCM DOUT)	(Don't use)

**Interface connector**

This connector is used for analog input. It uses the included 10-pin connector.

Connector type: DEGSON 15EDGKD-3.81-10P-13-00A(H)  
PHOENIX CONTACT FK-MCP 1.5/10-ST-3.81 (or equivalent)

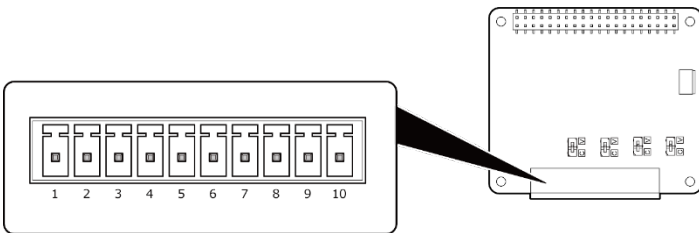

**Pin Assignment < Single-Ended Input (Voltage)>**

Pin No.	Signal Name	Description
1	AGND	This is an analog ground and shares channels of analog input signals.
2	AI7	Analog input signals. The numbers correspond to channel numbers.
3	AI6	Analog input signals. The numbers correspond to channel numbers.
4	AI5	Analog input signals. The numbers correspond to channel numbers.
5	AI4	Analog input signals. The numbers correspond to channel numbers.
6	AGND	This is an analog ground and shares channels of analog input signals.
7	AI3	Analog input signals. The numbers correspond to channel numbers.
8	AI2	Analog input signals. The numbers correspond to channel numbers.
9	AI1	Analog input signals. The numbers correspond to channel numbers.
10	AI0	Analog input signals. The numbers correspond to channel numbers.

**Pin Assignment < Differential Input (Voltage, Current)>**

Pin No.	Signal Name	Description
1	AGND	This is an analog ground and shares channels of analog input signals.
2	AI3(-)	Analog input signals (-). The numbers correspond to channel numbers.
3	AI3(+)	Analog input signals (+). The numbers correspond to channel numbers.
4	AI2(-)	Analog input signals (-). The numbers correspond to channel numbers.
5	AI2(+)	Analog input signals (+). The numbers correspond to channel numbers.
6	AGND	This is an analog ground and shares channels of analog input signals.
7	AI1(-)	Analog input signals (-). The numbers correspond to channel numbers.
8	AI1(+)	Analog input signals (+). The numbers correspond to channel numbers.
9	AI0(-)	Analog input signals (-). The numbers correspond to channel numbers.
10	AI0(+)	Analog input signals (+). The numbers correspond to channel numbers.

**Input switches**

The input switches are used to select whether to use the analog input port for voltage or current input. When using the port for current input, the input type must be set to differential input.

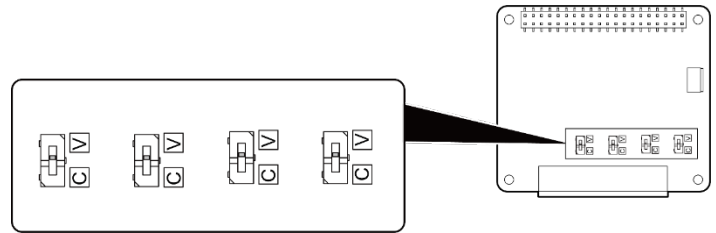

**Input switch settings**

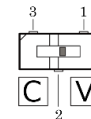

Switch number	Input method
1 - 2 (Factory settings)	Voltage input
2 - 3	Current input

\* The switch settings for voltage input and current input should be the same for all channels.

**Board ID setting switch**

This setting switch is used to identify I2C communication expansion cards. The Board ID setting switch can be used to switch I2C addresses. The following table shows the switch settings and the corresponding I2C addresses.

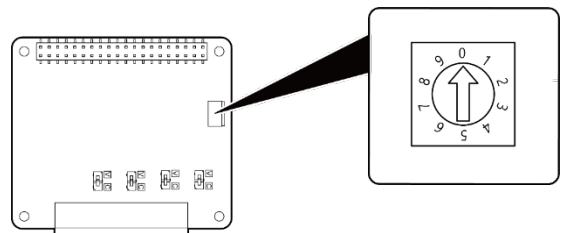

**Switch settings and the corresponding I2C addresses**

Setting the Board ID	Extended I/O (I2C1) I2C address	EEPROM(I2C0) I2C address
0	0x28 (Factory setting)	0x50 (Factory setting)
1	0x29	0x51
2	0x2A	0x52
3	0x2B	0x53
4*	0x2C	0x54
5	0x2D	0x55
6	0x2E	0x56
7	0x2F	0x57
8	Do not use this setting.	
9		

\* The Board ID setting switch cannot be set to 4 when using the CPI-RAS because the I2C address (0x2C) with this setting will overlap with the I2C address of the CPI-RAS.

## An example connection of single-ended voltage input

### [Connection using a flat cable]

The example below uses a flat cable to connect the Module to an external device. For each analog input channel, connect separate signal and ground wires on Connector.

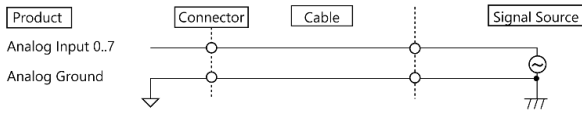

### [Connection using a twisted cable]

The example below uses a twisted cable to connect the Module to an external device. Use this type of cable if the external device is located at a distance from the product. For each analog input channel, connect input of the external device and ground wires on one-to-one basis.

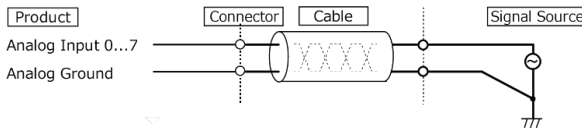

### [Connection using a coaxial cable]

The example below uses a coaxial cable to connect the Module to an external device. Use this type of cable if the distance between the signal source and the product is long.

For each analog input channel, connect the core wire to the signal line and connect the shielding to ground.

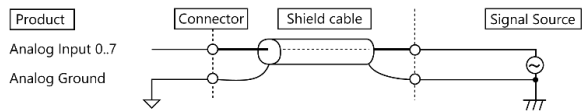

### [Connection using a shielded cable]

The example below uses a two-conductor twisted shield cable to connect the Module to an external device. Use this type of cable if the external device is located at a distance from the product or if the connection requires higher noise immunity. For analog input channel of the product and for ground, connect the core wire to the output of the external device and to ground respectively. Also, connect the shielding to ground.

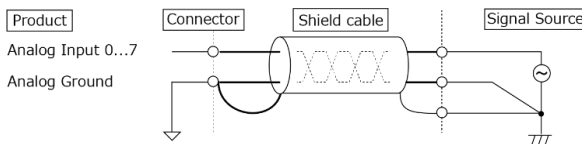

#### CAUTION

- If the signal source contains over 1MHz signals, the signal may affect the cross-talk noise between channels.
- If the cable between the product and the signal source is too long, data may not be input properly. The recommended cable length is within 1.5 meters.
- Analog input signal should not exceed the maximum input rating of the analog input voltage based on the analog ground. If it exceeds the maximum, this product may be damaged.
- When the input pin is not connected, conversion data is undefined. Connect all the unused analog input channels to analog ground.
- An input pin may fail to obtain input data normally when the signal source connected to the pin has high impedance. If this is the case, change the signal source to one with lower output impedance or insert a high-speed amplifier buffer between the signal source and the analog input pin to reduce the effect.

## An example connection of differential voltage input

### [Connection using a flat cable]

The example below uses a flat cable to connect the Module to an external device. For each analog input channel, connect the "+" input to the signal and connect the "-" input to the signal source ground. Also connect the analog ground on the module to the signal source ground.

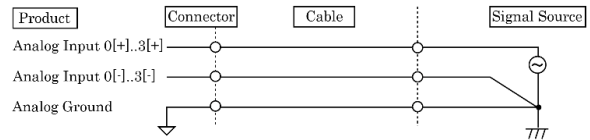

### [Connection using a twisted cable]

The example below uses a twisted cable to connect the Module to an external device. Use this type of cable if the external device is located at a distance from the product.

For each analog input channel, connect the "+" input to the signal and connect the "-" input to the signal source ground. Also connect the analog ground on the module to the "-" input.

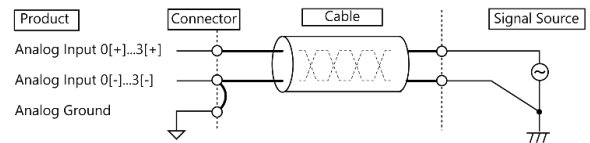

### [Connection using a shielded cable]

The example below uses a two-conductor twisted shield cable to connect the Module to an external device. Use this type of cable if the signal source is located at a distance from the Module or if the connection requires higher noise immunity. For each analog input channel, connect the "+" input to the signal and connect the "-" input to the signal source ground. Also connect the analog ground on the module and the signal source ground to the shielding.

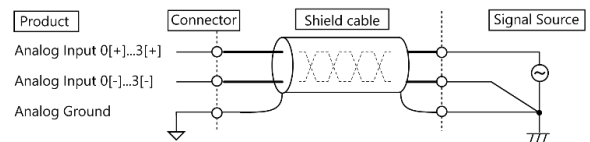

#### CAUTION

- If the signal source contains over 1MHz signals, the signal may affect the cross-talk noise between channels.
- When the analog ground is not connected, the conversion data is not determined.
- If the cable between the product and the signal source is too long, data may not be input properly. The recommended cable length is within 1.5 meters.
- Analog signal which input [+] Input, and [-] input should not exceed the maximum input rating of the analog input voltage. If it exceeds the maximum, this product may be damaged.
- When the pin of [+] input or [-] input is not connected, conversion data is undefined. Connect both the pin [+] input and [-] input of unused channels to analog ground.

## An example connection of differential current input

### [Connecting with two-terminal current output (using a flat cable)]

Connect the [+] analog input channel of the module to the positive side of the current source, and the [-] to the negative side of the current source respectively.

Also, connect the analog ground on the module to the [-] of the signal source.

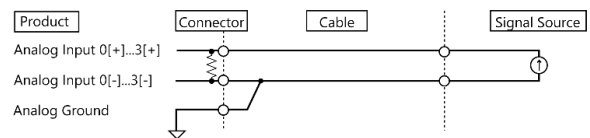

### [Connection using a twisted cable]

The example below uses a twisted cable to connect the Module to an external device. Use this type of cable if the external device is located at a distance from the product. Connect the [+] analog input channel of the module to the positive side of the current source, and the [-] to the negative side of the current source respectively. Also connect the analog ground on the module to the "-" input.

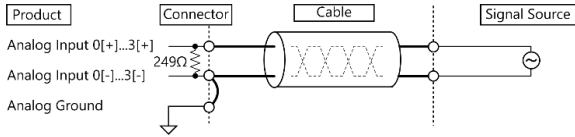

**[Connection using a shield cable]**

The example below uses a shielded two-conductor cable to connect the Module to an external device. Use this type of cable if the signal source is located at a distance from the Module or if the connection requires higher noise immunity and when the module is used in a place that is affected by lightning surge.

Connect the [+] analog input channel of the Module to the positive side of the current source, and the [-] to the negative side of the current source respectively. Also, connect ground of external device to ground of signal source using the shielding. At this time, make sure the potential difference between the [-] input of the Module and the analog ground is 0.5 V or less.

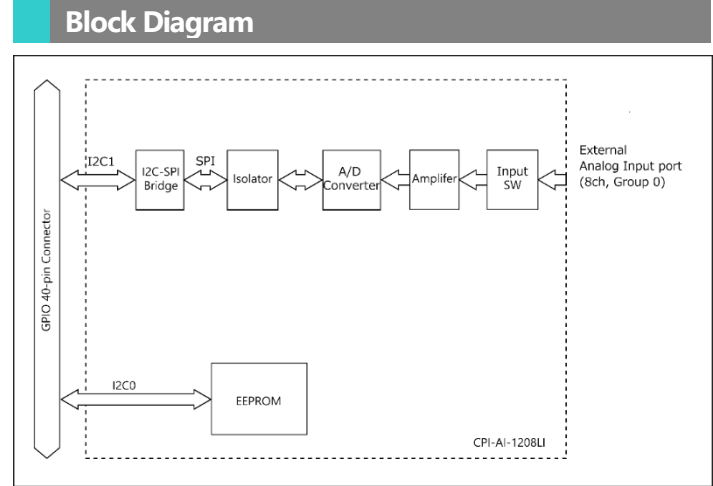
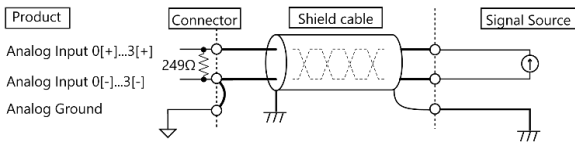

**An example connection with current output sensor**

**[2-Wire Sensor Connection]**

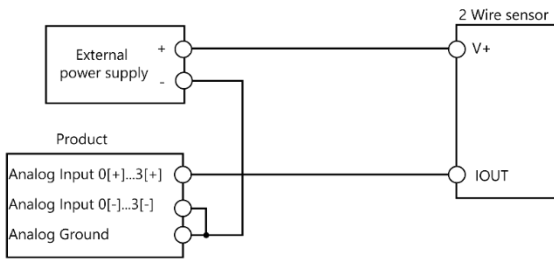

**[3-Wire Sensor Connection]**

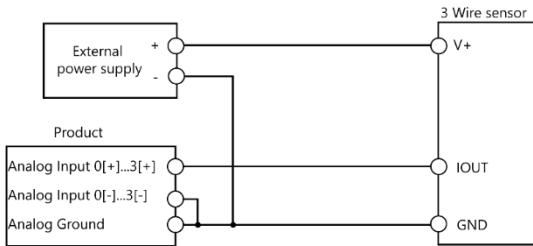

**CAUTION**

- If the signal source contains over 1MHz signals, the signal may affect the cross-talk noise between channels.
- When the analog ground is not connected, the conversion data is not determined.
- Analog ground is shared by channels as they are not isolated. If the channels are effected by potential differences, isolate the between the channel and channel with an isolation converter, for example.
- Analog signal which input [+] input, and [-] input should not exceed the maximum input rating of the analog input voltage. If it exceeds the maximum, this product may be damaged.
- When the pin of [+] input or [-] input is not connected, conversion data is undefined. Connect both the terminal [+] input and [-] input of unused channels to analog ground.