

Raspberry Pi Expansion Card RAS / RTC function card CPI-RAS



* Specifications, color and design of the products are subject to change without notice.

Features

RAS functionality for improved reliability, availability, and serviceability

This expansion card improves the reliability of Raspberry Pi devices by supplying clean power via the high-output, high-efficiency 5VDC 5A power supply and a noise filter for removing external noise. To improve availability, the expansion card automatically shuts down and restarts to minimize system downtime if the dedicated software or hardware detects a problem. The dedicated software also monitors various statuses for improved serviceability.

Real-time clock (RTC) with temperature compensation

RTCs without temperature compensation will usually be accurate in an environment of about 25°C. In low- or high-temperature environments, however, accuracy is likely to decrease due to the internal crystal characteristics. The RTC internal temperature compensation feature in this product improves the accuracy of time tracking in any temperature environment.

Support for a wide range of power supplies

This product supports external power supplies ranging from 8 - 28VDC (6 - 30V).

Power switch functionality

Add power switch functionality available in most PCs to the Raspberry Pi. The power switch can also be long-pressed to forcibly turn off the power. Operation is possible from the push switch on the product itself or from digital input via the interface connectors.

Timer interrupt for intermittent operation

Setting a start date and time using the RTC makes it possible to start the Raspberry Pi at a specific date and time. The included low power consumption power supply circuit also minimizes current consumption during shutdown.

External power supply function

Output connectors are available for outputting 8 - 28VDC power or 5VDC power, allowing external devices to be turned on or off according to the Raspberry Pi operation status.

Adaptable to a wide range of temperature between -20 and +60°C

The product is capable of operating in the temperature between -20 and + 60°C. It can be installed in the various environments.

This product is an expansion card that adds RAS functionality, RTC functionality, and 8 - 28VDC power supply input functionality to the Raspberry Pi.

*The contents in this document are subject to change without notice.
*Visit the CONTEC website to check the latest details in the document.
*The information in the data sheets is as of July, 2022.

Specifications

Function specification

Item	Description
Digital Input	
Input type	Non-isolated opto-coupler input (supports current sink output [negative logic] *1)
Number of input signal channels	2
Isolation	Non-isolated
Voltage Resistance	Non-isolated
Internal power supply	3.3V±5%
Input Resistance	Current-limiting : 220Ω, Shunt resistance : 1kΩ
Input ON current	64mA (Typ)
Input OFF current	0.16mA or less
Input signal voltage	3.3 - 28VDC
Digital Output	
Output type	Solid State Relay output
Number of output signal channels	1
Isolation	Solid State Relay isolation
Voltage Resistance	AC1000Vrms
Output rating	Output Voltage 28VAC/DC (Max) Output Current 200mA (Max)
ON resistance	2Ω or less (25°C)
OFF leak current	1μA or less (25°C)
External power supply output	
8 - 28VDC power supply output	Max. 2A (Output voltage varies according to DC power supply input voltage)
5VDC power supply output	5V±5% Max. 2A *2
Interface Connector	2 pieces 3.81mm pitch 10-pin terminal
Applicable wire	AWG26 - 16
LED	2-color LED (Green, Red)
Push switch	1
Hardware Monitor	8 - 28VDC input voltage, CPI-RAS board temperature
Bus specification	
Power supply output	5V±5% Max. 5A *2
Power supply input	3.3V±5% Max. 30mA
I2C bus (I2C1)	Used for 0x2c address and 0x32 address
Interrupt notification	
Function	Open collector output (Pull-up: 15kΩ)
Notification destination	Select from GPIO 4, 5, 6, or 22 (using DIP switch)
Power supply	
Rated input voltage	8 - 28VDC
Input voltage range	6 - 30VDC
Consumption power *3	<Product only>

Item	Description
	Without load : 8VDC 8.9mA (Typ), 12mA (Max) 28VDC 4.5mA (Typ), 5.9mA (Max) Shutdown: 8VDC 10uA (Typ) 28VDC 13uA (Typ) <Expanded interface> When Raspberry Pi + Expansion card + 5V external power supply output = 5A and 8 - 28V external power supply output = 0A : 8VDC 3.6A (Typ), 4.0A (Max) 28VDC 1.0A (Typ), 1.1A (Max)
Connector	2 pieces 3.5mm pitch 3-pin terminal (V+, V-, FG)
Applicable wire	AWG22 - 16
Physical dimensions (mm)	65.0(W) x 56.5(D) (No protrusions) Spacer height : 12.5mm
Weight	50g

- *1 Data "0" and "1" correspond to the High and Low levels, respectively.
- *2 The total current of the external power supply 5V output and GPIO 40-pin connector 5V output should be 5A or less.
- *3 The product is equipped with a fuse (rated current: 5A) for preventing overcurrent in the power supply input. Use a power supply that has overcurrent protection or that has a current capacity capable of blowing the fuse (9.5A or more is recommended).

Installation Environment Requirements

Item	Description	
Operating Temperature *4	-20 - +60°C	
Storage Temperature	-20 - +60°C	
Humidity	10 - 90%RH (No condensation)	
Floating dust particles	Not to be excessive	
Corrosive gases	None	
Line-noise resistance *5	Line noise	Signal Line /±1kV (IEC61000-4-4 Level 3, EN61000-4-4 Level 3)
	Static electricity resistance	Indirect discharge /±4kV (IEC61000-4-2 Level 2, EN61000-4-2 Level 2)
Vibration resistance	Sweep resistance	10 - 57Hz/semi-amplitude vibration 0.15mm, 57 - 150Hz/2.0G 40minutes each in X, Y, and Z directions (JIS C60068-2-6-compliant, IEC60068-2-6-compliant)
Shock resistance	15G half-sine shock for 11ms in X, Y, and Z directions (JIS C 60068-2-27 -compliant, IEC 60068-2-27 -compliant)	
Standard	VCCI Class A, FCC Class A, CE Marking (EMC Directive Class A, RoHS Directive), UKCA	

- *4 The 5V output current may be limited depending on the ambient temperature. Refer to the derating graph and make sure the current does not exceed the limit.
- *5 When using an optional power supply: 10 - 55Hz (For details, refer to the optional power supply manual).

Packing List

- Product [CPI-RAS] ...1
- 10-pin Connector ...1 (Attached to the product)
- 3-pin Pin-header...1 (Attached to the product)
- 40-pin Pin-header...1
- Plastic Spacer for CPU Card...1
- Hexagonal Spacers...4 (Height 12.5mm)
- Three-point Sems Screw...4
- Nuts...4
- Product Guide & Warranty Certificate...1
- Serial Number Label ...1

* This product is verified in conformity with our recommended power supply. In case you use other power supplies, thus, it may not be able to fulfil certification requirements. Please see the CONTEC website regarding power supply recommendation (<https://www.contec.com/>).

Support Software

You can use CONTEC support software according to your purpose and development environment. For more details on the supported OS, applicable languages, or to download the latest version of software, visit the CONTEC Web site.

Name	Contents	How to get
ARM Linux RAS driver	This is the Linux version driver software for providing RAS functionality in API function formats. The software includes various sample programs.	Download from the CONTEC website
ARM Linux RTC driver	This is the Linux version driver software for controlling RTC devices equipped in CPI-RAS products.	Download from the CONTEC website

Download the files from the following URL <https://www.contec.com/download/>

List of Option

Product Name	Model type	Description
AC adapter	PWA-65AWD9	Switching AC adapter 65W (Input: 100 - 240VDC, Output: 19VDC 3.42A)
DIN rail fitting power supply	CPS-PWD-30AW24-01	Fitting power supply 30W (Input: 100 - 240VDC, Output: 24VDC 1.3A)
	CPS-PWD-90AW24-01	Fitting power supply 90W (Input: 100 - 240VDC, Output: 24VDC 3.8A)
Expansion Card	CPI-DI-16L	Isolated Digital Input (Input: 16 points, supporting sink/source output)
	CPI-DO-16L	Isolated Digital Output (Output: 16 points, sink output)
	CPI-DO-16RL	Isolated Digital Output (Output: 16 points, source output)
	CPI-DIO-0808L	Isolated Digital Input/Output (Input: 8 points, Output: 8 points, sink output)
	CPI-DIO-0808RL	Isolated Digital Input/Output (Input: 8 points, Output: 8 points, source output)
	CPI-RRY-16	Solid State Relay Output (Output: 16 points)

* Information about the option products, see the Contec's website.

Physical Dimensions

Main body only

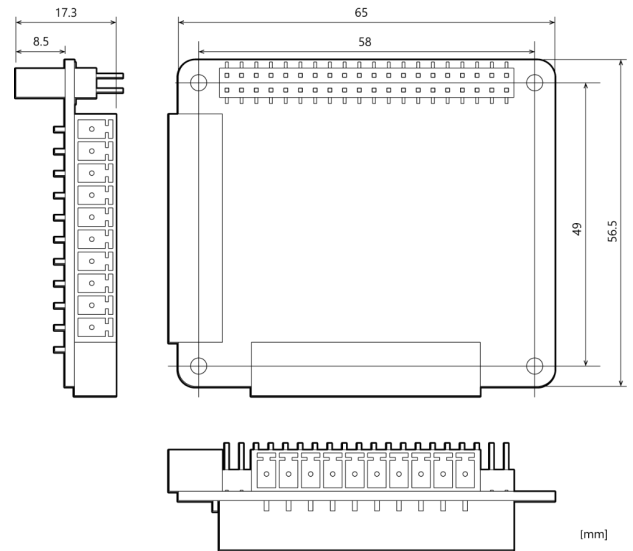

With connector attached

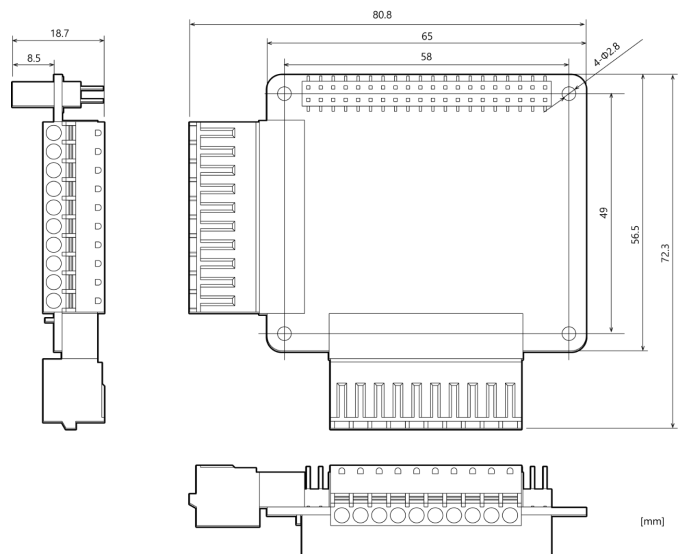

Component Name

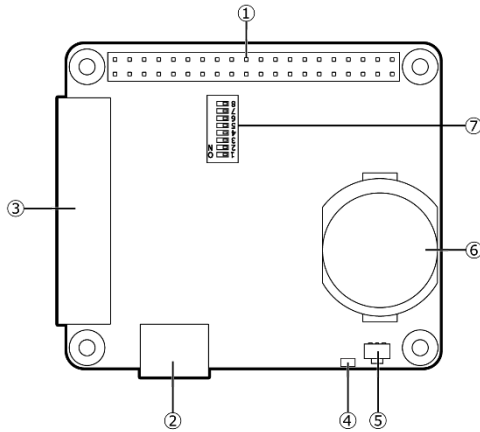

No.	Name	Function
1	GPIO 40 pin connector	This connector is used to connect to a Raspberry Pi or an expansion card.
2	DC power connector	This connector is used for power input. It uses the included 3-pin connector.
3	Interface connector	This connector is used for power supply output and digital input/output. It uses the included 10-pin connector.
4	LED Indicator	This indicator is used to display the operation status of the product.
5	Push switch	This switch is used to turn on/off the Raspberry Pi.
6	RTC battery	This is the primary RTC battery connector. The connector accepts a CR2032 battery.
7	DIP switch	This switch sets the GPIO pins to use for outputting the interrupt notification signal.

Connection to external devices

GPIO 40 pin connector

This connector is used to connect to a Raspberry Pi or an expansion card.

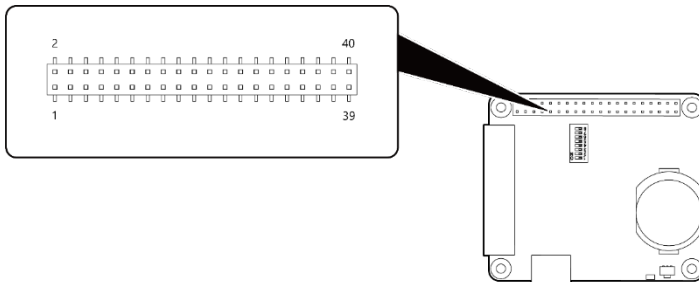

Pin Assignment

Pin No.	Signal Name	Description	Pin No.	Signal Name	Description
1	3.3V Power	3.3V power input	2	5V Power	5V±5% power output
3	GPIO 2(I2C1 SDA)	I2C1 SDA	4	5V Power	5V±5% power output
5	GPIO 3(I2C1 SCL)	I2C1 SCL	6	Ground	GND
7	GPIO 4(GPCLK0)	INT_1	8	GPIO 14(UART TX)	(Don't use)
9	Ground	GND	10	GPIO 15(UART RX)	(Don't use)
11	GPIO 17	(Don't use)	12	GPIO 18(PCM CLK)	(Don't use)
13	GPIO 27	(Don't use)	14	Ground	GND
15	GPIO 22	INT_2	16	GPIO 23	(Don't use)
17	3.3V Power	3.3V power input	18	GPIO 24	(Don't use)
19	GPIO 10(SPI0 MOSI)	(Don't use)	20	Ground	GND
21	GPIO 9(SPI0 MISO)	(Don't use)	22	GPIO 25	(Don't use)
23	GPIO 11(SPI0 SCLK)	(Don't use)	24	GPIO 8(SPI0 CE0)	(Don't use)
25	Ground	GND	26	GPIO 7(SPI0 CE1)	(Don't use)
27	GPIO 0(EEPROM SDA)	(Don't use)	28	GPIO 1(EEPROM SCL)	(Don't use)
29	GPIO 5	INT_3	30	Ground	GND
31	GPIO 6	INT_4	32	GPIO 12(PWM0)	(Don't use)
33	GPIO 13(PWM1)	(Don't use)	34	Ground	GND
35	GPIO 19(PCM FS)	(Don't use)	36	GPIO 16	(Don't use)
37	GPIO 26	(Don't use)	38	GPIO 20(PCM DIN)	(Don't use)
39	Ground	GND	40	GPIO 21(PCM DOUT)	(Don't use)

Interface connector

The interface connector includes an external power supply output, two digital inputs, and one digital output. It uses the included 10-pin connector.

Connector type: DEGSON 15EDGKD-3.81-10P-13-00A(H)
PHOENIX CONTACT FK-MCP 1.5/10-ST-3.81 (or equivalent)

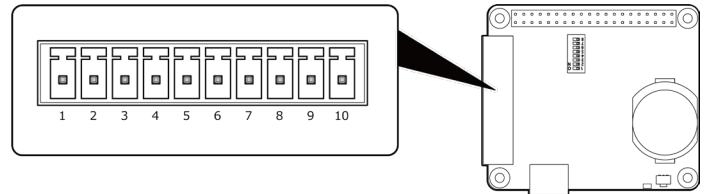

Pin Assignment

Pin No.	Signal Name	Description
1	DO-	This indicates the output signals. This contact is connected to the negative (-) side of the input signals of other devices.
2	DO+	This indicates the output signals. This contact is connected to the positive (+) side of the input signals of other devices.
3	DI1-	This indicates the input signals. This contact is connected to the negative (-) side of the output signals of other devices.
4	DI1+	This indicates the input signals. This contact is connected to the positive (+) side of the output signals of other devices.
5	DI0-	This indicates the input signals. This contact is connected to the negative (-) side of the output signals of other devices.
6	DI0+	This indicates the input signals. This contact is connected to the positive (+) side of the output signals of other devices.
7	5V external power supply -	This contact outputs voltage at 5V ±5% on the software setting. (Power ON : 0V)
8	5V external power supply +	This contact outputs voltage at 5V ±5% on the software setting. (Power ON : 0V)
9	8 - 28V external power supply -	This contact outputs the input voltage from the DC power supply connector on the software setting. (Power ON : 0V)
10	8 - 28V external power supply +	This contact outputs the input voltage from the DC power supply connector on the software setting. (Power ON : 0V)

DC power connector

The included 3-pin power connector is used for connecting an external power supply.

Connector type: DEGSON 15EDGKD-3.5-03P-13-00A(H)
PHOENIX CONTACT FK-MCP1,5/3-ST-3,5 (or equivalent)

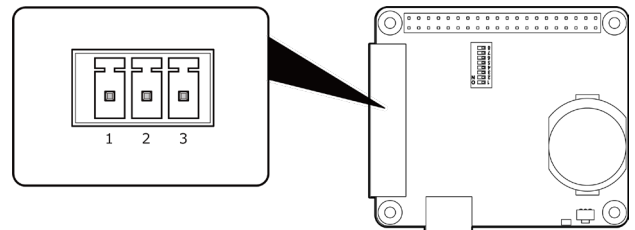

Pin Assignment

Pin No.	Signal Name	Description
1	FG	Frame ground
2	V-	GND
3	V+	8 - 28VDC

DIP switch

This switch sets the GPIO pins to use for outputting the interrupt notification signal.

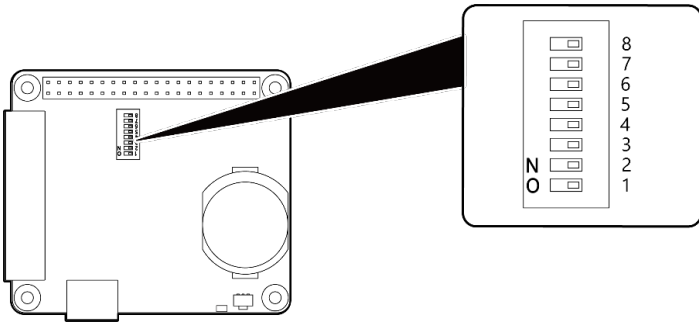

Pin No.	Signal Name	Operation	Description
1	INT_1	OFF	Interrupt notification signal not connected to GPIO4 (Pin 7) (Factory setting)
		ON	Interrupt notification signal connected to GPIO4 (Pin 7)
2	INT_2	OFF	Interrupt notification signal not connected to GPIO22 (Pin 15) (Factory setting)
		ON	Interrupt notification signal connected to GPIO22 (Pin 15)
3	INT_3	OFF	Interrupt notification signal not connected to GPIO5 (Pin 29) (Factory setting)
		ON	Interrupt notification signal connected to GPIO5 (Pin 29)
4	INT_4	OFF	Interrupt notification signal not connected to GPIO6 (Pin 31)
		ON	Interrupt notification signal connected to GPIO6 (Pin 31)
5	Reserved	OFF	Reserved for system; Leave to OFF.
6	Reserved	OFF	Reserved for system; Leave to OFF.
7	Reserved	OFF	Reserved for system; Leave to OFF.
8	Reserved	OFF	Reserved for system; Leave to OFF.

Block Diagram

