

CONPROSYS Series
IO-Link Master Module (8-channel)
CPSL-08P1EN



* Specifications, color and design of the products are subject to change without notice.

Features

Multi-protocol support

This product supports industrial Ethernet protocols of differing makers, and can connect to the network of PROFINET, EtherNet/IP, Modbus TCP, CC-Link IE Field Basic, EtherCAT, and OPC UA with the switches on the product.

8 channels of independent IO-Link port

8 channels of IO-Link port (Class A) allow parameters to be set independently, and IO-Link mode and SIO mode can be set per port. In addition, digital input during IO-Link communication is achievable since No.2 pin of IO-Link port can be used as a digital terminal.

Easy settings through a web browser

Network settings and status check can be easily done through a web browser on the network from your PC.

Adaptable to a temperature range between -20 and +60°C

The product is capable of operating in the temperature between -20 and + 60°C. It can be installed in the various environments.

IP67 dust-proof and water-proof features

With its dust-proof and water-proof design to meet the IP67 rating, the product can be used in locations subject to water or dust particles.

(*IP67 is the performance indication when the waterproof caps specified by the CONTEC are set to all connectors.)

M12 power connector adopted

As for a power connector, M12 power connector (L-Coded) is adopted. It supplies a large amount of power with its compact size. This product also has a FG terminal (functional grounding) for a power connector.

Output terminal for power supply

The power input in the power input terminal is branched and it will be output from the power output terminal. Since it can be used as the power for other devices, you can connect them in the daisy-chain connection.

Equipped with LED for an operation check

The product has LED for an operation check, which helps you visually confirm the communication status of each interface.

Installation on the wall with screws

The product can be installed on the wall with screws.

This product is an IO-Link Master module with 8 channels of IO-Link port (Class A). It supports industrial Ethernet protocols of differing makers and can connect to the network of PROFINET, EtherNet/IP, Modbus TCP, CC-Link IE Field Basic, EtherCAT, and OPC UA with the switches on the product.

8 channels of IO-Link port (Class A) allow parameters to be set independently, and IO-Link mode and SIO mode s can be set per port.

As this product has a web server function, the user can install the functions through a Web browser without using a specific tool.

* The contents in this document are subject to change without notice.

* Visit the CONTEC website to check the latest details in the document.

* The information in the data sheets is as of September, 2020.

Specifications

Function specifications < 1 / 2 >

Item		Specifications
LAN	Transmission standard	100BASE-TX
	Data rate	10/100Mbps
	The number of ports	2
	Connector	M12(D-coded, Female, 4-pin)
	LED	ACT(Orange), LINK(Green)
IO-Link	Transmission scheme	IO-Link protocol (Ver.1.0/Ver.1.1)
	The number of ports	8
	Connector	M12(5-pin A-Coded, Female) *1
	Communication speed	COM1: 4.8kbp, COM2: 38.4kbps, COM3: 230.4kbps
	Port class	Type A
	Rated voltage	24VDC (typ.)
	Max. load current	200mA/port *2
	Isolation specification	Non-isolated
	LED	A(Orange),ST(Green/Red), B(Orange)
IO-Link (in SIO(DI)mode)	Input type	Current source output (PNP output) support
	Rated voltage	24VDC (typ.)
	Input current	5mA (typ.)
	ON/OFF voltage	15VDC min. / 5VDC max. *3
IO-Link (in SIO(DI) mode)	Output type	Push-pull output *3
	Rated voltage	24VDC (typ.)
	Output current	200mA/port *2
	Output registance	3Ω max.
IO-Link (Digital inputs for pin 2)	Input type	Current source output (PNP output) support
	Rated voltage	24VDC (typ.)
	Input current	2mA (typ.)
	ON/OFF voltage	15VDC min. / 5VDC max. *3
LED		ST(Green/Red), BF/NS/ERR(Green/Red), SF/MS/RUN(Green/Red), SYS(Green, Orange)
Switch		Mode setting switch, Address setting selection switch, Address setting switch×2, Protocol setting switch

*1 Connector pin 5 is left unconnected.

*2 The total current of the C/Q, L+ line in all ports should be less than 1.6A.

*3 Data 0 corresponds to Low level and Data 1 corresponds to High level.

Function specifications < 2 / 2 >

Item		Specifications
Power input *4*5	Rate input voltage (current)	U _S : 24VDC (1.8A), U _A : 24VDC (0.1A)
	Max. input current	U _S : 12A, U _A : 12A
	Input voltage range	U _S : 20.4 - 26.4VDC, U _A : 20.4 - 26.4VDC
	Device current consumption	U _S : 0.2A(Max.), U _A : 0.1A(Max.)
	Connector	M12(5-pin(4+FE) L-Coded, Male)
Power output *4	Output voltage *6	U _S : U _S input voltage (Max.), U _A : U _A input voltage (Max.)
	Max. output current *7	U _S : 12A, U _A : 12A
	Connector	M12(5-pin(4+FE) L-Coded, Female)
Physical dimensions (mm)		69.0(W)×225.0(D)×18.0(H) (No projection included)
Weight		600g
Protective function		IP67 *8
Installation method		Installation with screws *9

- *4 Use power cable within 3meters.
- *5 UA power is unavailable with this product. It is not necessary to supply power to UA when you only use the device on its own.
- *6 The voltage input to the power input terminal is output as it is, but if the current from the output terminal is large, a voltage drop may occur due to the internal resistance.
- *7 The total current from the power output current, device consumption current, and output current to the IO-Link port should be supplied to the power supply input terminal.
- *8 Do not use this product immersed in water.
- *9 The commercial screws are required individually.

Installation Environment Requirements

Item		CPS-MM-LC
Operating ambient temperature		-20 - +60°C
Operating ambient humidity		10 - 90%RH (No condensation)
Non-operating ambient temperature		-20 - +60°C
Non-operating ambient humidity		10 - 90%RH (No condensation)
Corrosive gases		None
Line-noise resistance	Line noise	AC line/±2kV *10 Signal line/±1kV(IEC61000-4-4 Level 3, EN61000-4-4 Level 3)
	Static electricity resistance	Touch/±4kV(IEC61000-4-2 Level 2, EN61000-4-2 Level 2) Air/±8kV(IEC61000-4-2 Level 3, EN61000-4-2 Level 3)
Vibration resistance (The product alone) *9	Sweep resistance	10 - 57Hz *11 / semi-amplitude vibration 0.15mm, 57 - 150Hz/2.0G 40minutes each in X, Y, and Z directions (JIS C60068-2-6-compliant, IEC60068-2-6-compliant)
Altitude		5000m or less
Shock resistance (The product alone) *10		15G half-sine shock for 11ms in X, Y, and Z directions (JIS C 60068-2-27-compliant, IEC 60068-2-27-compliant)
Grounding		Class D grounding (previous class 3 grounding)
Standard		VCCI ClassA, FCC ClassA, CE Marking(EMC Directive Class A, RoHS Directive)

- *10 When you use the CPS-PWD-90AW24-01 (optional power product)
- *11 When you use an optional power product : 10 - 55Hz (See the manual of optional power product for details)

Physical Dimensions

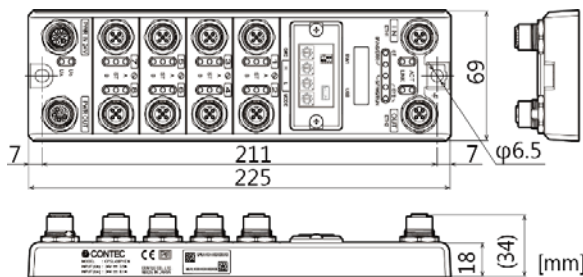

Circuit Block Diagram

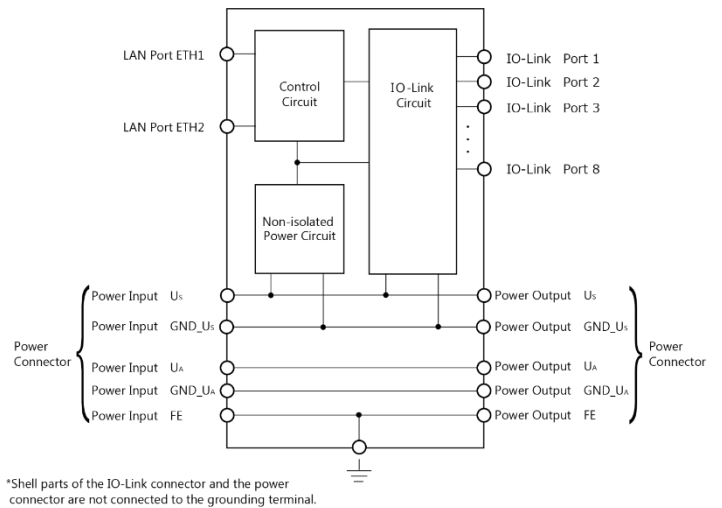

*Shell parts of the IO-Link connector and the power connector are not connected to the grounding terminal.

Component Name

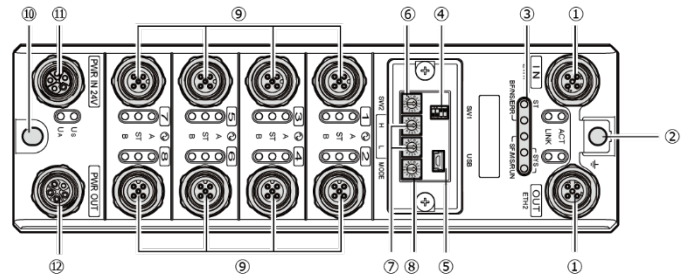

No.	Name	Function
1	LAN Port	It is a connector for Ethernet communication.
2	FE Terminal	It is a terminal for functional grounding. (This hole is also used to secure the main body with a screw).
3	Status LED	Status of the product is indicated with LEDs.
4	Mode Setting Switch	It is a switch for boot mode setting. (Do not perform any operations other than those described in this manual.)
5	Maintenance Connector	Do not use this.
6	Address Setting Selection Switch	It is a switch to select a setting method for the IP address of the product.
7	Address Setting Switch	It is a switch to set an address of the product.
8	Protocol Setting Switch	It is a switch to select an Ethernet protocol.
9	IO-Link Connector	It is an IO-Link communication connector.
10	Screw Mounting Hole	It is a hole to fix and secure the main body with a screw.
11	Power Input Connector	It is a connector to supply power.
12	Power Output Connector	It is a connector to send power to the outside.

LAN Port

Pin number	Signal number	Description
1	TX+	Transmission data (+) Output
2	RX+	Reception data (+) Input
3	TX-	Transmission data (-) Output
4	RX-	Reception data (-) Input

- LAN Cable

Compatible Connector	M12, 4-pin D-Coded (For Ethernet), Male
Category	Category 5e or better, a shielded cable (Double shield cable recommended)
Cable Length	Within 100 meters

Protocol Setting Switch

	Setting value	Setting contents
	0 [Factory settings]	PROFINET
	1	EtherNet/IP
	2	Modbus TCP
	3	CC-Link IE Field Basic
	4	EtherCAT
5 - F	Do not set anything.	

Address Setting Selection Switch

	Setting value	Setting contents
	0 [Factory settings]	DHCP *1
	1	BOOTP *2
	2	When using the product with fixed addresses.(192.168.1.1 -192.168.1.254). Set with the address setting switch. *1
3 - F	Do not set anything.	

*1 Do not set this when setting PROFINET protocol / EtherCAT protocol.

*2 Do not set this except when setting EtherNet / IP protocol.

Address Setting Switch

Set this when using the product with fixed addresses.(192.168.1.1 -192.168.1.254). *1*2 Set an IP address when choosing [2] in "Address Setting Selection Switch". *3 There are two switches for setting addresses and the addresses are set in hex. "H" and "L" represent high bits and low bits respectively. The setting range is 01 - FEh (1 - 254). The address is read when the product power is turned on. When changing the address, change the settings first, then, reboot the product.

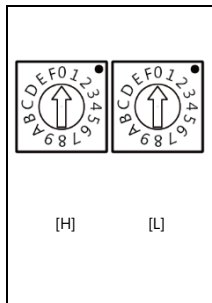

- Settings for the Address Setting Switch (EtherNet/IP, Modbus TCP, CC-Link IEF Basic)

Setting value	Setting contents
00h [Factory settings]	Start up with the IP address set in CONPROSYS WEB Setting.
01 - FEh FFh	It is a setting range for addresses. Set to "FF" and turn on the power. This restores IP address to the default settings. The SYS of the LED turns green. Check the green is on, and set back to "00", then start up again.

- Settings for the Address Setting Switch (EtherCAT)

Setting value	Setting contents
00h [Factory settings]	The configuration station system is used for setup.
01 - FF	Explicit Device ID can be set in the range of [0-255]. Always set Configuration Station Alias to [0] when setting ID.

*1 Do not set this when the protocol setting switch is selecting PROFINET.

*2 Node ID can be set instead of IP address when the protocol setting switch is selecting EtherCAT.

*3 Set [0] when the protocol setting switch is selecting EtherCAT.

IO-Link Connector

Pin number	Signal name	Description
1	L+	Power supply to the connected device (+)
2	DI	Digital input
3	L-	Power supply to the connected device (-)
4	C/Q	IO-Link communication/Digital I/O
5	N.C.	This is left unconnected

- IO-Link Cable

Compatible Connector	M12, 3 to 5-pin (in accordance with your use) A-Coded, Male
Cable	Use a cable that withstands the temperature of 75°C and higher.
Cable Length	Within 20 meters

- An example of connecting with the IO-Link device

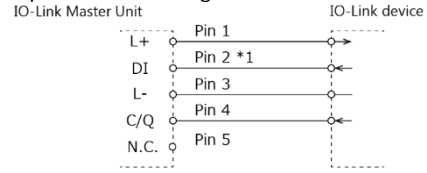

*1 As for an IO-Link device without a Pin 2 digital input function, it will be unconnected on the IO-Link device side and digital input data will be always off.

- An example of connecting with a 3-line sensor

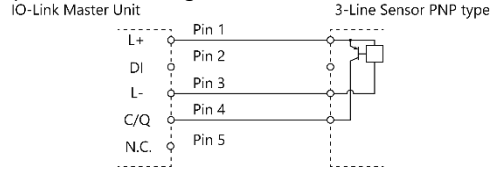

- An example of connecting with a 2-line sensor

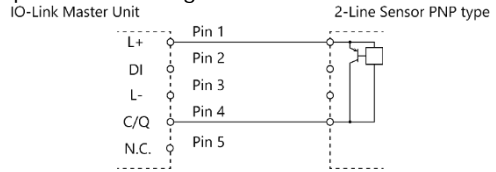

- A connecting example of DO output

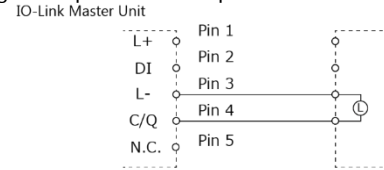

Power Input Connector

Pin number	Signal name	Description
1	U _S	I/O power /system power
2	GND_U _A	Ground of the auxiliary power
3	GND_U _S	Ground of I/O power/system power
4	U _A	Auxiliary power (Unavailable with this product)
FE	FE	It is a terminal for functional grounding. Connect this to earth ground.

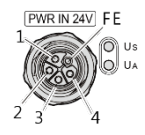

- Power Input Cable

Compatible Connector	M12, 5-pin(4+FE) L-Coded, Female
Cable	Use a cable that withstands the temperature of 75°C and higher.
Cable Length	Within 3 meters

Power Output Connector

Pin number	Signal name	Description
1	U _S	I/O power/system power
2	GND_U _A	Ground of the auxiliary power
3	GND_U _S	Ground of I/O power/system power
4	U _A	Auxiliary power
FE	FE	It is a terminal for functional grounding. It is connected to the FG terminal at the top of the device.

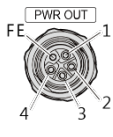

- Power Output Cable

Compatible Connector	M12, 5-pin(4+FE) L-Coded, Male
Cable	Use a cable that withstands the temperature of 75°C and higher.
Cable Length	Within 3 meters

Product Configuration List

Product ...1	Product Guide ... 1
Warranty Certificate ...1	Serial number Label ...1
Waterproof cap ...1	

Optional Products

DIN rail fitting power supply

CPS-PWD-90AW24-01:	Fitting power supply 90W (Input: 100 - 240VAC, Output: 24VDC 3.8 A)
CPS-PWD-30AW24-01:	Fitting power supply 30W (Input: 100 - 240VAC, Output: 24VDC 1.3 A)

Unshielded cable with a connector on one end for M12 (L-Coded) connector

PCL5P-3:	M12, 5-pin (4+FE) L-Coded, Female, one end, 3m
----------	--

- * When connecting to the optional power supply of the CONTEC, alterations need to be undertaken to connect the M12 connector cable to the terminal.
- * Visit the Contec website for the latest optional products.