

N Series for USB
Isolated Digital I/O Unit(8ch Relay Output, 8ch DI)
DIO-0808RN-USB



*The above photograph is DIO-1616HN-USB.

* Specifications, color and design of the products are subject to change without notice.

Features

Diverse installations such as screw fastening, magnet, DIN rail are possible

Installation on the floor / wall /ceiling is possible by screw fastening, magnet, rubber feet, etc.

In addition, DIN rail mounting mechanism is equipped as standard with the product, making it easy to install the product within the panel or the device.

Compact design not restricting installation location (188.0(W) x 78.0(D) x 30.5(H))

Compact design of 188.0(W) x 78.0(D) x 30.5(H) does not require special installation location

Easy-to-wire terminal connector adopted

Adoption of terminal connector (with screws) enables to achieve easy wiring.

Relay outputs (Form C) with independent common

This product has 8 channels of SPDT relay outputs (Form C) with independent common.

Independent common terminal provided per channel, capable of supporting a different external power supply. High-capacity output rating is designed to be a maximum of 6A 240V (AC), 5A 28V (DC) per channel.

Optocoupler isolated input (compatible with current sink output/current source output)

This product has 8 channels of Optocoupler isolated inputs (compatible with current sink output/current source output) whose response speed is 200μsec, supporting driver voltages of 12 - 24 VDC for input. 8 channels share one common.

Opto-coupler isolation and relay isolation

As the USB I/F on PC is isolated from the input interfaces by opto-couplers and output interfaces by relays, this product has excellent noise performance.

Compatible to USB1.1/USB2.0

Compatible to USB1.1/USB2.0 and capable to achieve high speed transfer at HighSpeed (480 Mbps).

Windows compatible driver libraries are attached.

Using the attached digital I/O driver API-DIO(WDM) makes it possible to create applications of Windows. In addition, a diagnostic program by which the operations of hardware can be checked is provided.

LabVIEW is supported by a plug-in of dedicated library VI-DAQ.

Using the dedicated library VI-DAQ makes it possible to make a LabVIEW application.

This product is an USB2.0-compliant digital I/O unit that extends the input function of digital signal from the USB port of PC and output signals to SPDT relay contacts.

This product is compatible with input digital signals at 12 - 24VDC which features 8 channels of Optocoupler isolated inputs (compatible with current sink output/current source output) and 8 channels of SPDT relay outputs with independent common.

Compact design not restricting installation location (188.0(W) x 78.0(D) x 30.5(H)) makes it easy to install the product within the panel or device using DIN rail mounting jigs, or on the floor or wall.

Windows driver library is supplied. Possible to be used as a data recording device for LabVIEW, with dedicated libraries.

*Visit the CONTEC website to check the latest details in the document.

*The information in the data sheets is as of January, 2023.

Specification

Item	Specification	
Input		
Number of input signal channels	8 channels (1 common)	
Input format	Opto-isolated input (Compatible with current sink / current source output) (Negative logic *1)	
Input resistance	4.7kΩ	
Input ON current	2.0mA or more	
Input OFF current	0.16mA or less	
Response time	Within 200μsec *2	
Dielectric strength	500Vrms	
Dielectric strength *5	12 - 24VDC (±10%)	
Output		
Number of output signal channels	8 channels (independent common)	
Output format	SPDT Relay Output (Form C)	
Relay Contact Spec.	Max. rating capacity	6A 240VAC, 5A 28VDC (load resister)
	Max. permitted voltage	240V (Max.) *7, *8
	Max. Carry Current	5A (Max.)
	Contact resistance (Initial state)	100mΩ max.
	Operate time	Within 10ms
	Release time	Within 5ms
	Mechanical Life Expectancy	10,000,000 operations min or more Switching times : 300 operations/min
	Electrical Lifetime	50,000 operations min. Switching times : 30 operations/min
	Relay Type	G6RL-1
USB section		
Bus specification	USB Specification 2.0/1.1standard	
USB transfer rate	12Mbps (Full-speed), 480Mbps (High-speed) *3	
Power supply	Bus Power	
Common section		
Number of terminals used at the same time	127 terminals (Max.) *4	
Current consumption (Max.)	5VDC 430mA	
Operating conditions *6	0 - 50°C, 10 - 90%RH (No condensation)	
Allowable distance of signal extension	Approx. 50m (depending on wiring environment)	
Physical dimensions (mm)	188.0(W)×78.0(D)×30.5(H) (No protrusions)	
Weight	300g (Not including the USB cable, attachment)	
Connector	10 pin (screw-terminal) plug header x4	
Attached cable	USB Cable 1.8m	
Standard	VCCI Class A, FCC Class A, CE Marking (EMC Directive Class A, RoHS Directive), UKCA	

*1 Data "0" and "1" correspond to the High and Low levels, respectively.

*2 The Optocoupler's response time comes.

*3 This depends on the PC environment used (OS and USB host controller).

*4 As a USB hub is also counted as one device, you cannot just connect 127 USB units.

*5 External circuit power supply is required.

*6 To suppress the heating, ensure that there are spaces for ventilation (about 5cm) around this product.

*7 Please don't exceed either max. permitted voltage or max. rating capacity of the use relay when using it by the voltage that exceeds 28VDC. Doing so can cause a malfunction.

*8 The potential difference between channels must not exceed 240V in the maximum. Doing so can cause a malfunction.

Support Software

Windows version of digital I/O driver API-DIO(WDM)

It is the library software, and which supplies command of hardware produced by our company in the form of standard Win32 API function (DLL). Using programming languages supporting Win32API functions, such as Visual Basic and Visual C++ etc., you can develop high-speed application software with feature of hardware produced by our company. In addition, you can verify the operation of hardware using Diagnostic programs.

You can download the updated version from the CONTEC's Web site. For more details on the supported OS, applicable language and new information, please visit the CONTEC's Web site.

Data acquisition VI library for LabVIEW VI-DAQ (Available for downloading (free of charge) from the CONTEC web site.)

This is a VI library to use in National Instruments LabVIEW. VI-DAQ is created with a function form similar to that of LabVIEW's Data Acquisition VI, allowing you to use various devices without complicated settings.

See CONTEC's Web site for details and download of VI-DAQ.

Packing List

- Unit [DIO-0808RN-USB] ...1
- USB cable (1.8m) ...1
- USB cable attachment on the main unit's side (For Mini B connector side) ...1
- Please read the following ... 1
- I/O connector...4
- Rubber feet ...4
- Magnet ...2

Block Diagram

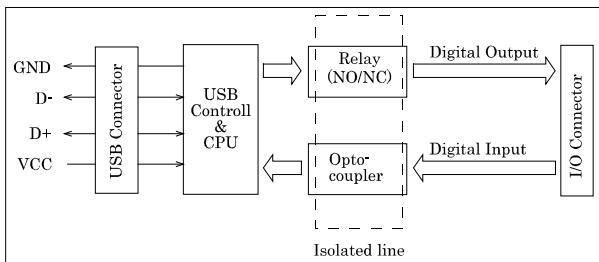

Physical Dimensions

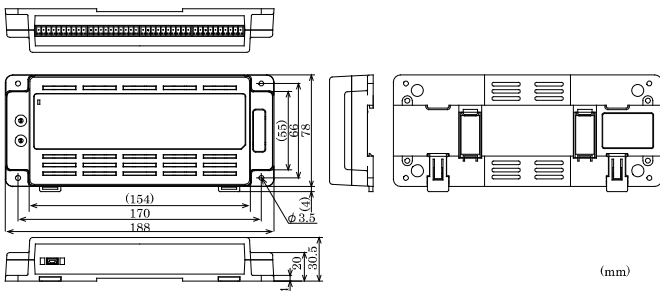

Installation Method

Mounting on a DIN Rail

Mounting procedure

- (1) Push the fixing hook up using a slotted screwdriver to make it unlockable.

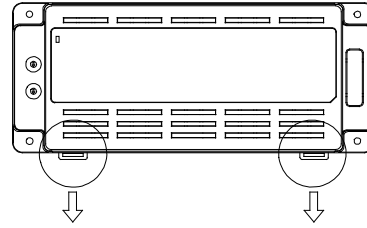

- (2) Hook the product from the upper part of the DIN rail, and press the lower part on to the DIN rail.

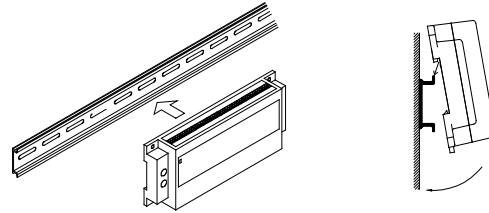

- (3) Push the fixing hook up using a slotted screwdriver to make it lockable.

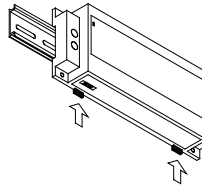

Removal procedure

(1) Pull down the fixing hook of the unit to unlock it.

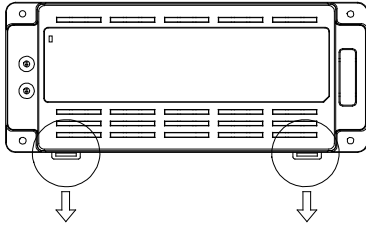

(2) With the fixing hook unlocked, pull the lower part of this unit toward you.

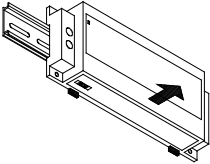

(3) By lifting this unit, you can easily remove it from the DIN rail.

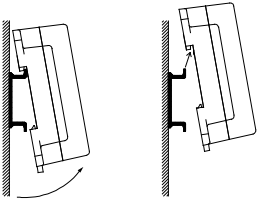

Desktop Installation Using the rubber feet

When required to mount the product on the desktop, mount it on a horizontal platform.

The rubber feet can be mounted in their mounting holes as shown in the following figure.

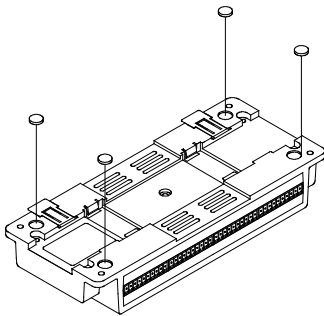

Wall Installation

To mount the product on the wall, purchase the commercially available screw (fitting for $\phi 3.5$) separately.

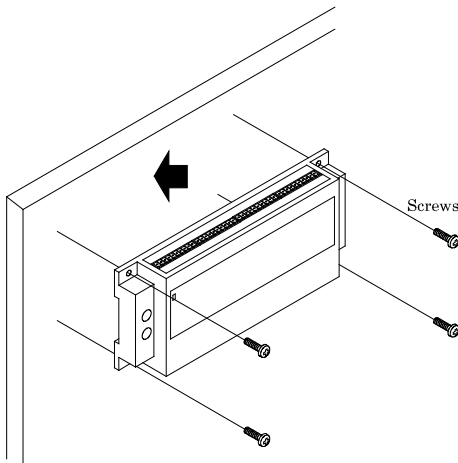

Installation Using the Magnet

Attaching the magnet supplied with the product makes it easy to mount or remove the product on or from a metal surface such as steel desk or partition.

⚠ CAUTION

Do not let the magnet go near objects that can be affected by magnetic fields, such as monitors and floppy disks.

If the product is shifted while mounted on the steel surface, the surface paint may be scratched.

When using the magnet, stack connection is not possible.

Mounting/ removing the magnet

To mount the magnet, press down the entire length of the magnet into its mounting hole while pushing the magnet in the direction of arrow 1. Next, slide the magnet in the direction of arrow 2 to fix it in position.

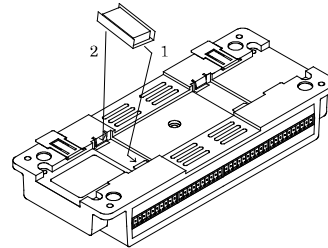

To remove the magnet, slide the magnet in the direction of arrow 1 as shown in the following figure, and then lift it out in the direction of arrow 2.

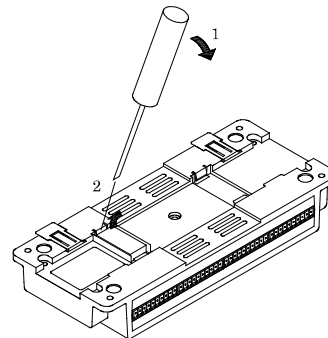

Mounting onto the steel wall

Mount the product directly onto the steel wall. Pull it gently after mounting to confirm that it will not drop off from the body.

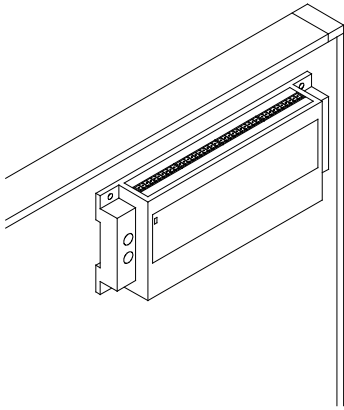

Installation Conditions

Installation orientation

It is possible to mount it in the orientations shown in the following figure. Other orientations would cause problems in usage, such as inadequate heat dissipation.

DIN rail fixation

Vertical installation

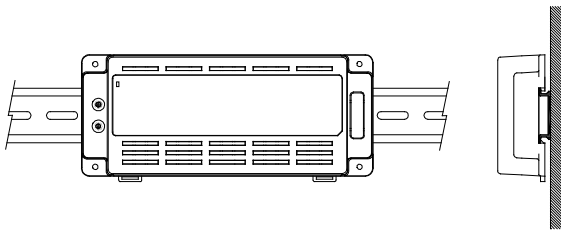

Horizontal installation

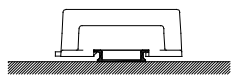

Installation on a ceiling

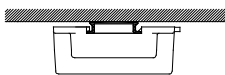

Screws / magnet fixation

Vertical installation

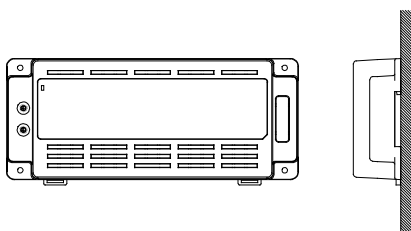

Horizontal installation

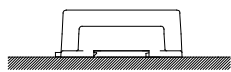

Installation on a ceiling

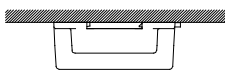

CAUTION

When using the product in a high temperature environment, cool it by blowing air even when the temperature is within the specified range.

Spacing between the system unit and any surrounding objects

Secure a distance of at least 50mm between the top of the main unit (single use) and any surrounding objects.

Do not locate the unit in a fully enclosed housing.

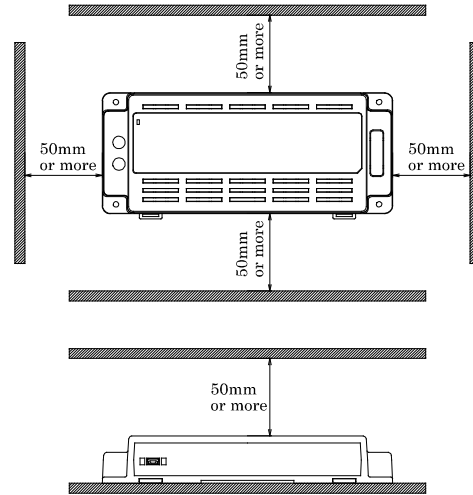

Connection Method

Connecting an Interface Connector

When connecting the unit to an external device, you can use the supplied connector plug. For wiring, strip off approximately 7 mm of the covered part of a wire rod and then insert it to the opening. After the insertion, secure the wire rod with screws. Compatible wires are AWG 28 - 16.

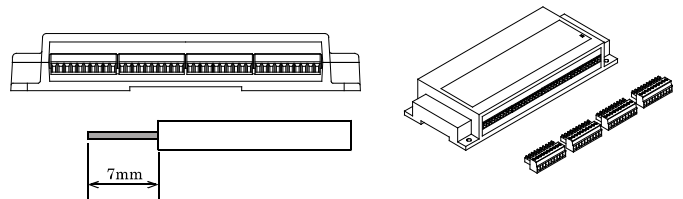

- Connector used :
3.5mm pitch, 10 pin type of rated current 9.0A
STL1550/10G-3.5-H-GREEN [mfd. by PTR]
- Compatible plug (supplied) :
AK1550/10-3.5-GREEN [mfd. by PTR]
Compatible wires : AWG28-16

CAUTION

Removing the connector plug by grasping the cable can break the wire.

Signal Layout

Signal Layout on the Interface Connector

The unit can be connected to an external device using 10-pin connectors that is provided on the unit face.

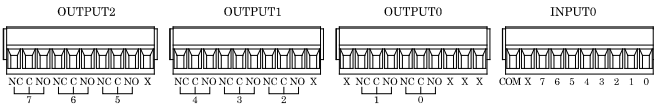

Pin No.	Signal Name	Logical Bits	Logical Ports	Meaning	Pin No.	Signal Name	Logical Bits	Logical Ports	Meaning
0	IN00	0		Input	X	N.C.	None	None	Not Connected
1	IN01	1			NO-2	NO-2	2		Output
2	IN02	2			C-2	C-2			
3	IN03	3			NC-2	NC-2			
4	IN04	4			NO-3	NO-3	3		
5	IN05	5			C-3	C-3			
6	IN06	6			NC-3	NC-3			
7	IN07	7			NO-4	NO-4	4		
X	N.C.	None	None	None	None	None	None	None	Not Connected
COM	COM	None	None	Plus/Minus Common for INPUT0	NC-4	NC-4			
X	N.C.	None	None	Not Connected	X	N.C.	None	None	Not Connected
X	N.C.	None	None	Not Connected	NO-5	NO-5	5		Output
X	N.C.	None	None	Not Connected	C-5	C-5			
NO-0	NO-0	0		NC-5	NC-5				
C-0	C-0			NO-6	NO-6	6			
NC-0	NC-0			C-6	C-6				
NO-1	NO-1	1		NC-6	NC-6				
C-1	C-1			NO-7	NO-7	7			
NC-1	NC-1			C-7	C-7				
X	N.C.	None	None	Not Connected	NC-7	NC-7			

IN00 - 07	8 input signal pins. Connect output signals from the external device to these pins.
NO-0 - 7	8 output signal pins (Normally Open [NO]). Connect these pins to the input signal pins of the external device.
NC-0 - 7	8 output signal pins (Normally Close [NC]). Connect these pins to the input signal pins of the external device.
C-0 - 7	Common pins for 8 output signals (Common for Normally Open [NO] and Normally Close [NC]).
N.C.	This pin is left unconnected.
COM	Common pins for 8 input signals. These pins are common to either positive side or negative side of external signals.

Connecting Input Signals

Input Circuit

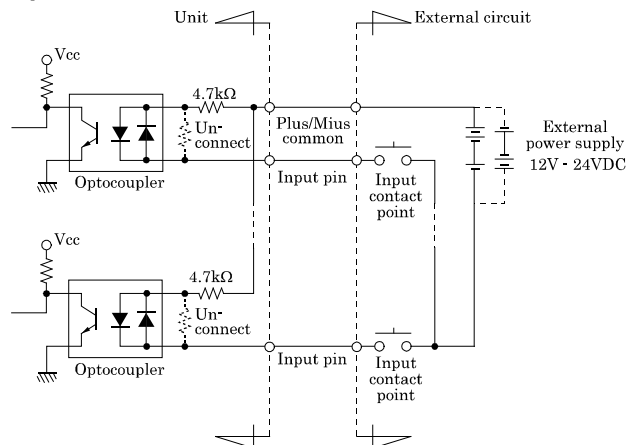

The input circuit of interface blocks of this product are illustrated in the above figure.

The signal inputs are isolated by Optocouplers (compatible with both current sink type and current source type output).

The board therefore requires an external power supply to drive the inputs. The power capacity required for driving each input channel is about 5.1mA when the signal voltage is 24 VDC or about 2.6mA when the signal voltage is 12 VDC.

Example of Connection

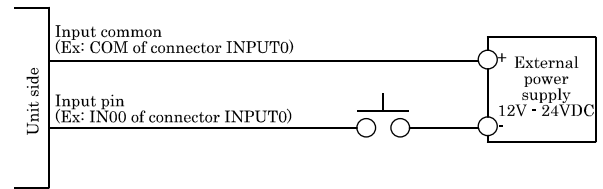

When the switch is ON, the corresponding bit contains 1.
When the switch is OFF, by contrast, the bit contains 0.

Connecting Output Signals

Output Circuit

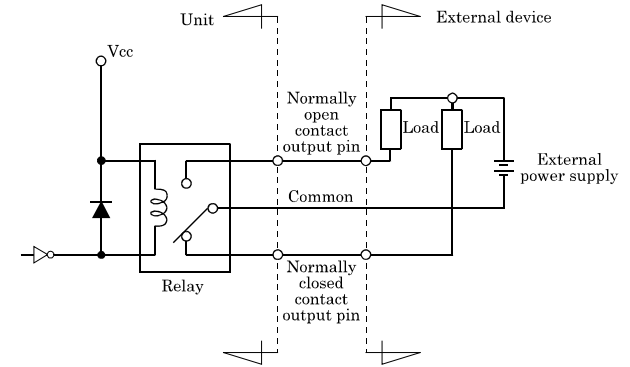

The output circuits of interface blocks of this product are illustrated in the above figure.

The signal outputs are independent common relay outputs (Form C) using a rated output current of up to 6A 240V (AC), 5A 28V (DC) per channel.

CAUTION

When power on, normally open (NO) outputs are OFF status (break status) and normally close (NC) outputs are ON status (make status).

Connection to the LED

- When the output logic bit0 is 1

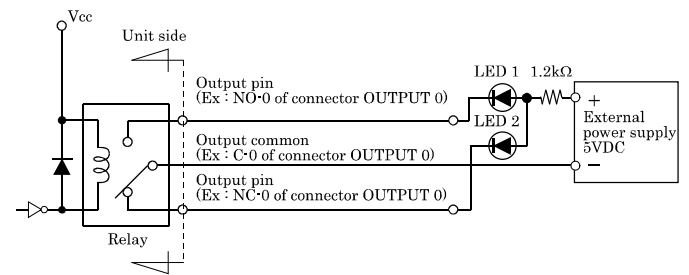

As a result, setting output NC-0 to "ON" state (make status), LED1 goes out and LED2 comes on.

- When the output logic bit0 is 0

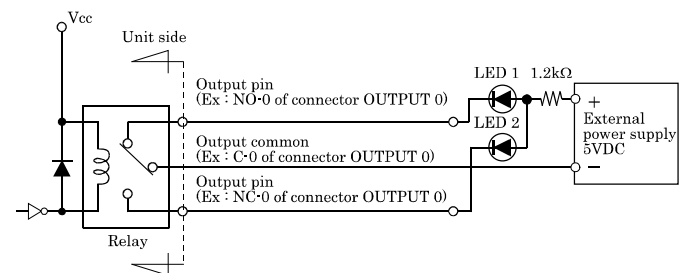

As a result, setting output NO-0 to "ON" state (make status), LED1 comes on and LED2 goes out.